

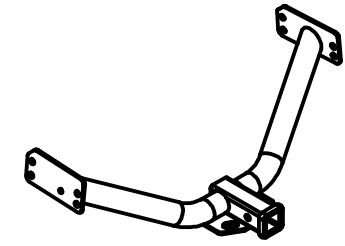

Class III Receiver Hitch

Part No. 69576C



Fits: ACURA MDX (EXCEPT FULL SIZE SPARE)



GROSS LOAD CAPACITY WHEN USED AS A WEIGHT CARRYING HITCH: 4,000 LBS. TRAILER WEIGHT & 400 LBS. TONGUE WEIGHT.
GROSS LOAD CAPACITY WHEN USED AS A WEIGHT DISTRIBUTION HITCH: 5,000 LBS. TRAILER WEIGHT & 500 LBS. TONGUE WEIGHT

WARNING: * DO NOT EXCEED VEHICLE MANUFACTURER'S RECOMMENDED TOWING CAPACITY. *****



Parts List			
ITEM	QTY	PART NUMBER	DESCRIPTION
1	4	M14 - 1.5 x 35 HEX	HEX BOLT
2	4	9/16" CONICAL WASHER	CONICAL TOOTHED WASHER
3	4	M14 - 1.5 x 40 HEX	HEX FLANGE BOLT

TOOLS REQUIRED	
3/8" DRIVE RATCHET	
22mm - 3/8" DRIVE SOCKET	
10mm - 3/8" DRIVE SOCKET	
TORQUE WRENCH	

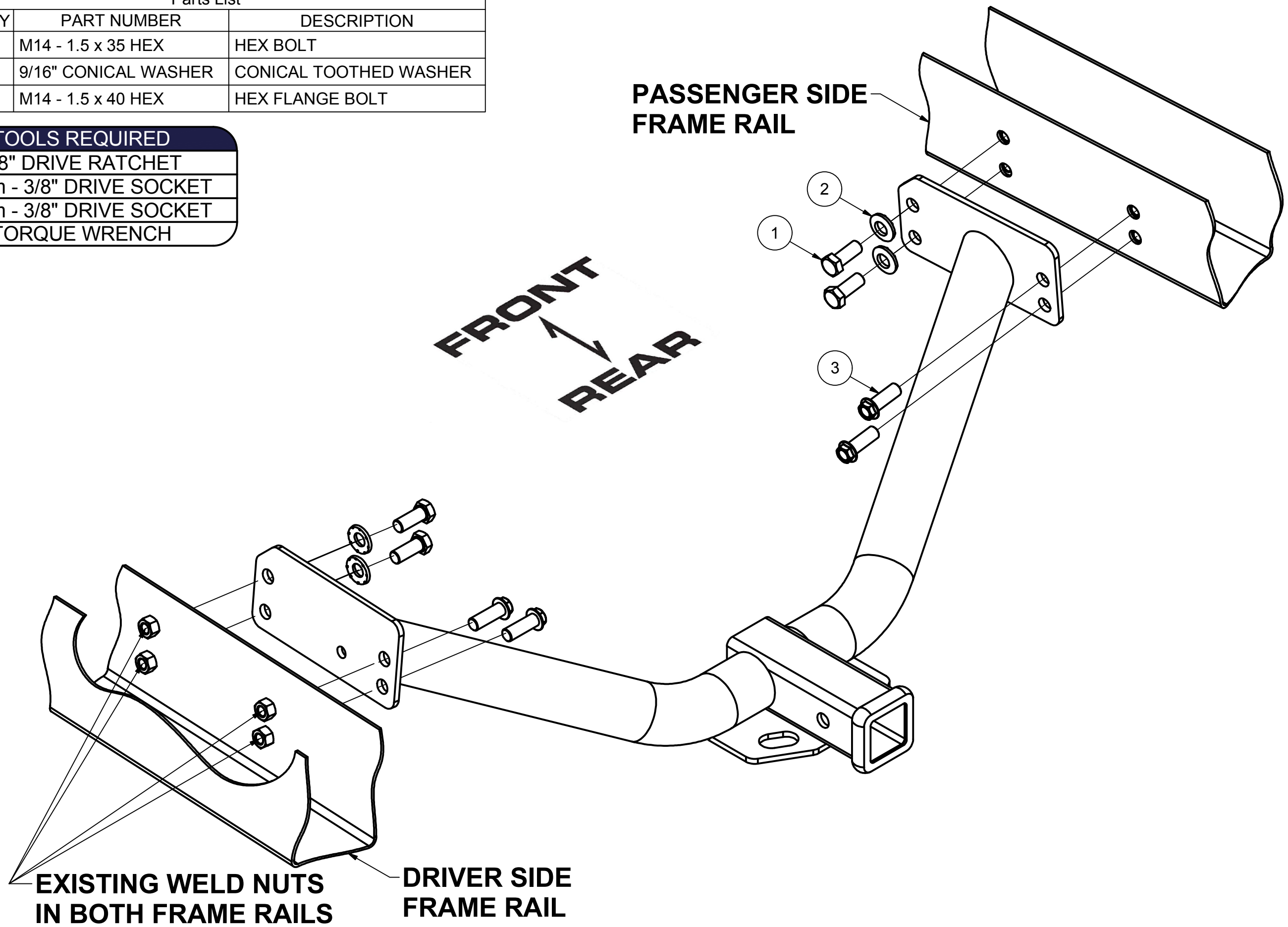

HITCH WEIGHT: 28 LBS.

INSTALL TIME

PROFESSIONAL: 30 MINUTES

NOVICE (DIY): 60 MINUTES

INSTALL NOTES:

- NO DRILLING REQUIRED
- LOWER SPARE TIRE AND EXHAUST
- REMOVE / RE-INSTALL HEAT SHIELD

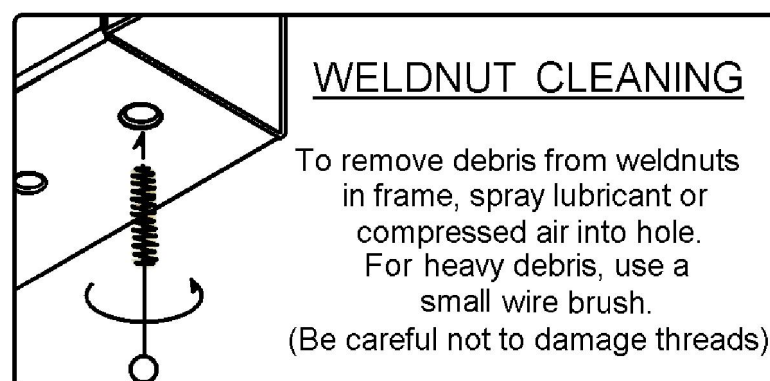

CONICAL TOOTHED WASHER ORIENTATION DIAGRAM

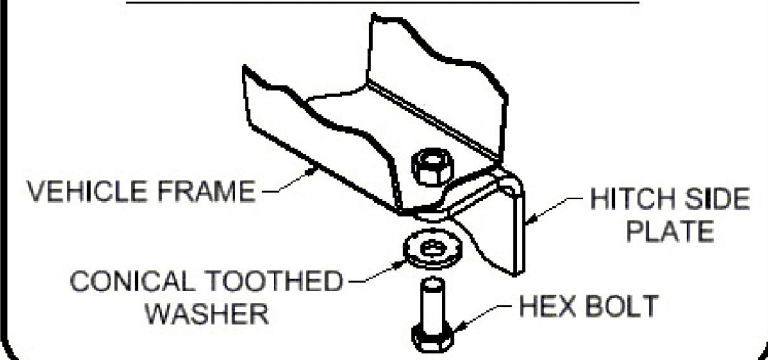

INSTALLATION STEPS

- 1) Remove the muffler hanger to allow the exhaust to drop down. Remove spare tire and muffler heat shield to ease installation.
Note: Retain heat shields and hardware for re-installation.
- 2) Raise hitch into position between frame rails and install fasteners as shown above.
- 3) Torque all 14mm fasteners to 136 lb-ft.
- 4) Re-install heat shield and spare tire (if removed), and re-attach muffler hangers.

PERIODICALLY CHECK THIS RECEIVER HITCH TO ENSURE THAT ALL FASTENERS ARE TIGHT AND THAT ALL STRUCTURAL COMPONENTS ARE SOUND.

Keystone Automotive Operations Inc., warrants this product to be free of defects in material and/or workmanship at the time of retail purchase by the original purchaser. If the product is found to be defective, Keystone Automotive Operations Inc., may repair or replace the product, at their option, when the product is returned, prepaid, with proof of purchase. Alteration to, misuse of, or improper installation of this product voids the warranty. Keystone Automotive Operations Inc.'s liability is limited to repair or replacement of products found to be defective, and specifically excludes liability for incidental or consequential loss or damage. This product complies with safety specifications and requirements for connecting devices and towing systems of the state of New York, V.E.S.C. Regulation V-5 and SAE J684. For Technical & Warranty Support: 1-877-544-4449 Fax- 1-855-242-8922 www.huskytow.com

11202017